

**HARDKORR**  
L I F E S T Y L E

## AUTOMOTIVE LIGHTS



**INSTRUCTION MANUAL**  
AND INSTALLATION GUIDE

Congratulations on purchasing this high quality Hardkorr product.

In doing so, you now have the assurance and peace of mind that comes from purchasing a product that has been manufactured to the highest quality standards.

Our aim is for you to be completely satisfied with your purchase, and therefore your new Hardkorr product is backed by a comprehensive 12 month warranty and an outstanding after-sales customer service team.

We hope you will enjoy using this product for many years to come.

If you require technical support, or in the unlikely event your purchase appears to be faulty, please contact our support team for immediate assistance. You can find up-to-date contact details on our website **hardkorr.com**.

General Information and Safety Instructions ..... 4  
Specifications ..... 5  
Installation Instructions ..... 6-7  
Frequently Asked Questions ..... 8  
Warranty ..... 9-10

## INTRODUCTION



### PLEASE KEEP THIS MANUAL FOR FUTURE REFERENCE

This manual contains important safety instructions for your Hardkorr Lifestyle Driving Lights.

Do not install or operate the driving lights unless you have read and understood this user manual. Pay particularly close attention to CAUTION and WARNING statements.

Hardkorr recommends that the driving lights be installed by an appropriately qualified professional.

### DISCLAIMER

While caution has been taken to ensure the accuracy of the contents of this guide, Hardkorr assumes no responsibility for errors or omissions.

Please note that specifications and functionality may change without notice.

### MODELS COVERED BY THIS MANUAL

#### **HKLS1100**

*HARDKORR LIFESTYLE 8.5" LED DRIVING LIGHTS (PAIR W/HARNESS)*

#### **HKLS700**

*HARDKORR LIFESTYLE 7" LED DRIVING LIGHTS (PAIR W/HARNESS)*

#### **HKLS600**

*HARDKORR LIFESTYLE 22" LED LIGHT BAR*

**WARNINGS**

Failure to follow these instructions may result in personal/property injury, and/or a reduced life of the product.

- Do not disassemble the lights.
- Do not look directly into the lights.
- Do not connect the light to power systems greater than 12V.
- Do not run more than three lights off the one harness.
- Do not connect the light to a power source greater than 30V.
- Do not use a pressure washer to clean the lights. Do not use solvent-based cleaners when washing the lights.
- Hardkorr recommends the installation of the lights to be performed by a licensed auto electrician.
- Some vehicles will require a different piggyback adaptor than the ones included, or may need to be hardwired into place. We recommend checking with the vehicle manufacturer before installing the lights.
- Before mounting your lights, refer to your state/territory's laws and regulations around the use and installation of the lights.
- Ensure your lights are mounted tightly and securely.
- Improper installation of the wiring harness will affect the performance and reliability of the light.
- Consider the airflow to the radiator before installing the lights.
- Do not install the driving lights in a place that may interfere with the driver's line of vision.
- The installation, positioning, and use of the driving lights is solely the responsibility of the user.

## SPECIFICATIONS

**HARDKORR**

	<b>HK LS1100</b>	<b>HK LS700</b>	<b>HK LS600</b>
<b>LED NUMBER (EACH)</b>	15 x 4W	9 x 4W	40 x 5W
<b>DISTANCE</b>	1 lux @ 1,100m (pair)	1 lux @ 700m (pair)	1 lux @ 600m
<b>OUTPUT</b>	19,000 raw Lumens (pair)	11,800 raw Lumens (pair)	15,000 raw Lumens
<b>BEAM</b>	Spot	Spot	Combination
<b>INGRESS PROTECTION</b>	IP68	IP68	IP67
<b>WEIGHT (EACH)</b>	2.3kg	1.8kg	1.9kg
<b>OPERATING VOLTAGE</b>	10-30v DC	10-30v DC	10-30v DC
<b>CURRENT</b>	10A @ 12V / 5A @ 24V (pair)	6A @ 12V / 3A @ 24V (pair)	12A @ 12V / 6A @ 24V
<b>COLOUR TEMP.</b>	6000K	6000K	6000K
<b>CERTIFICATIONS</b>	CE, EMC, CISPR15	CE, EMC, CISPR15	CE, EMC, CISPR15

## DIMENSIONS

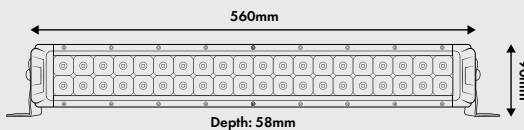
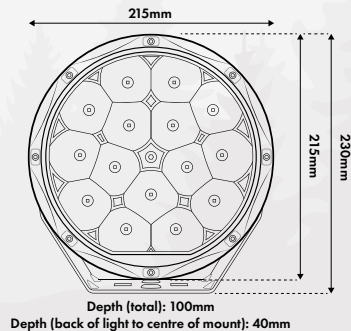
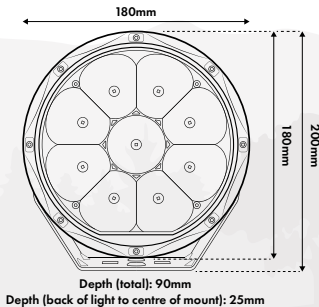

*These instructions are applicable to the HKLS1100 and HKLS700 driving lights only; the HKLS600 require the purchase of a separate harness. To install the HKLS600 you will need to follow the installation instructions provided with that harness.*

- Prior to installing the lights on your vehicle, Hardkorr recommends testing the lights and wiring harness outside of the vehicle.
- Disconnect the battery.
- If you do not have pre-drilled holes, sit the lights on the mounting surface, mark where the holes will need to be placed, and then remove the light and drill the holes. There are three mounting holes in each bracket; you can choose to use either one or three bolts per light. Using three bolts may provide additional stability in extreme conditions.
- Mount the bottom plate of the bracket through to the bullbar, roof rack or other surface, with the rubber pad in-between.
- Connect the Deutsch plug from the LED lights to the matching plugs on your wiring harness.
- Remove the high beam plug from the back of your headlight and connect it to the piggyback adaptor - the kit has a H3 and H4 adaptor supplied, however other adaptors are available for purchase separately if your vehicle has a different plug (note that some vehicles require a model-specific piggyback adaptor). You'll then need to connect the adaptor to the white plug on the harness.
- Next, feed the switch to the inside of the cabin. This should be through a rubber grommet that runs through the firewall. To do this, you'll need to note the order of the wires on the back of the switch, then remove, reconnecting once in the cabin of your vehicle.
- Secure the relay to the body of the vehicle then connect the positive and negative terminals from the harness to your battery.

# INSTALLATION INSTRUCTIONS

**HARDKORR**

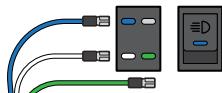

1

**BLUE WIRE - HIGH BEAM POSITIVE +**  
**WHITE WIRE - SWITCHED POSITIVE +**  
**GREEN WIRE - NEGATIVE -**

FIREWALL

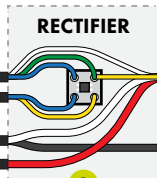

3

9 10

2

11 12



4

8

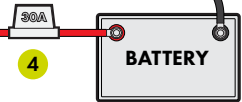

5



7

6

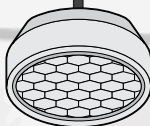

1 - WHITE WIRE  
 2 - BLACK WIRE

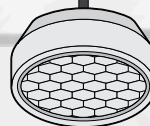

1	Power switch and pin-out
2	12V/24V Relay (See 9-12 for pinout)
3	Rectifier (Found within wrapped section)
4	30A inline blade fuse
5	Piggyback adapter (H4 adapter shown)
6	Dual output DT plugs

7	Vehicle headlights
8	Vehicle battery
9	Relay pin 87
10	Relay pin 30
11	Relay pin 86
12	Relay pin 85

**Q. How do I turn on my lights?**

A. Wired correctly, the lights will require the high beams to be turned on before the switch will activate the lights.

**Q. How do I adjust the tilt of the driving lights?**

A. Loosen the bolts either side of the lights to the point where the lights are tiltable. From there you'll be able to angle the light to your desired position.

**Q. What's the best way to clean my lights?**

A. Keeping the lenses of the light clean will increase the performance of the light. We recommend using a sponge and a bucket of warm soapy water to wash the lights down. Please note, that using a solvent-based cleaner is not recommended and may void the warranty of the light.

**Q. My driving lights are working only while on the low beam setting. Why is it doing this?**

A. Depending on the make of your vehicle the lights may need to be wired differently. In this case, we recommend contacting the manufacturer, or, alternatively, getting an auto electrician to wire the lights in.

**Q. The lights don't seem to be working correctly. What do I do?**

A. There are typically a few reasons why this would be the case:

- 1) The lights have been incorrectly wired up - we would recommend getting a qualified auto electrician to get this set up for you.
- 2) Each vehicle is wired differently. For every installation, we recommend contacting the manufacturer to check on the best way to wire the lights in.
- 3) Check the fuse and relays. For the fuse, if you're seeing a gap in the wire or a dark smear this'll mean that it's blown and needs replacing. To test the relay, we recommend connecting it up to a multimeter.

**Have another question for us? We're happy to help.**

You can get in contact with our support team via the email:  
[info@hardkorr.com](mailto:info@hardkorr.com)



## WARRANTY

**HARDKORR**

Our goods come with guarantees that cannot be excluded under the Australian Consumer Law. You are entitled to a replacement or refund for a major failure and compensation for any other reasonably foreseeable loss or damage. You are also entitled to have the goods repaired or replaced if the goods fail to be of acceptable quality and the failure does not amount to a major failure.



Hardkorr warrants that this product will be free from defects in material and workmanship for one year. The warranty commences on the date of purchase by the original purchaser, and is not transferable. To access the benefits of this warranty, you must retain your proof of purchase and follow any other direction we reasonably give you (e.g. completing and returning your warranty card if applicable).

### TO BEGIN YOUR WARRANTY CLAIM

If you believe your Hardkorr product is defective, it must be returned to Hardkorr for inspection by our warranty claims department.

1. You must have a Return Authorization (RA) number. To get your RA number, please complete the form found on our website and wait for the warranty team to contact you.
2. Once you have an RA number, you must arrange for the product must be shipped at your own expense back to Hardkorr (keep your receipt). The address for shipment will be provided when we issue your RA number.
3. Please be sure that your RA number is clearly marked on the outside of the packaging used for shipping.

Completing the steps as mentioned will ensure a faster process of your claim, so that Hardkorr can get your product back to you as soon as possible.

Once we receive your returned product, our technicians will inspect it. We will then notify you of the outcome of your claim.

If we accept your warranty claim, we will either repair, replace or refund the goods at our discretion. We will also reimburse you for the shipping costs you incurred in sending the goods back to us. Any products that we choose to replace or refund become the property of Hardkorr.

If we do not accept your claim, we will advise you of the reason and hold your product for collection. You will need to arrange and pay for the product to be shipped back to you. If your product is not collected within 30 days of your warranty claim being finalised, we may destroy it. Your warranty is voided if we (at our sole discretion) determine that there is evidence of one or more of the following:

- **Negligence:** Improper installation, improper or extreme use, use that contravenes this instruction manual, etc.
- **Abuse:** Road hazards, Damage beyond the limits of "normal wear and tear."
- **Unauthorized Repair:** Repair service performed by an unauthorised service centre.
- **Disassembly:** Any attempt to open, tamper with or otherwise compromise the integrity of the product.
- **Consequential damage:** damage to this product caused by the failure of another component of the vehicle or device in which this product is installed.

**Exterior Finish:** Hardkorr uses the highest quality materials available, but depending on location, environment and exposure, the colour of exterior surfaces can fade. We will not approve any warranty claims that relate to fade.

## DISCONTINUED ITEMS

Discontinued items that are still under warranty will be reviewed by Hardkorr. If a discontinued item is covered under warranty it may be replaced by an equivalent or superior item. If an equivalent item is not available Hardkorr will determine terms of resolution on a case-by-case basis.



**HARDKORR**

**HARDKORR.COM**